

## 3443 - 118 Locator Plate

### Instructions for the Assembly of 2mm x 2mm Preassembled Socket Connectors using Locator Plate 3443-118

#### General

The 2mm Locator Plate 3443 - 118 is designed to aid in the assembly of the preassembled socket connector family for all positions. End to end as well as daisy chain assemblies can be made (min. daisy chain length 24mm).

**Note:** Staging Platform is optional (Part No. 3767-0005).

Locator Plate includes:

- 2 mounting screws.
- Instruction sheet.

#### Tool preparation

1. Mount the lever ① on the guiding wing ② and secure by locking screw ③. Make sure that the plastic ball is facing towards the operator (see drawing on back).
2. Adjust air pressure for 3M assembly press model # 3830 to 80 PSI.
3. Place locator plate on the press and fix it by means of the two locking screws included.

**Note:** If staging platform (optional) is used, please refer to its own instruction sheet for mounting instructions.

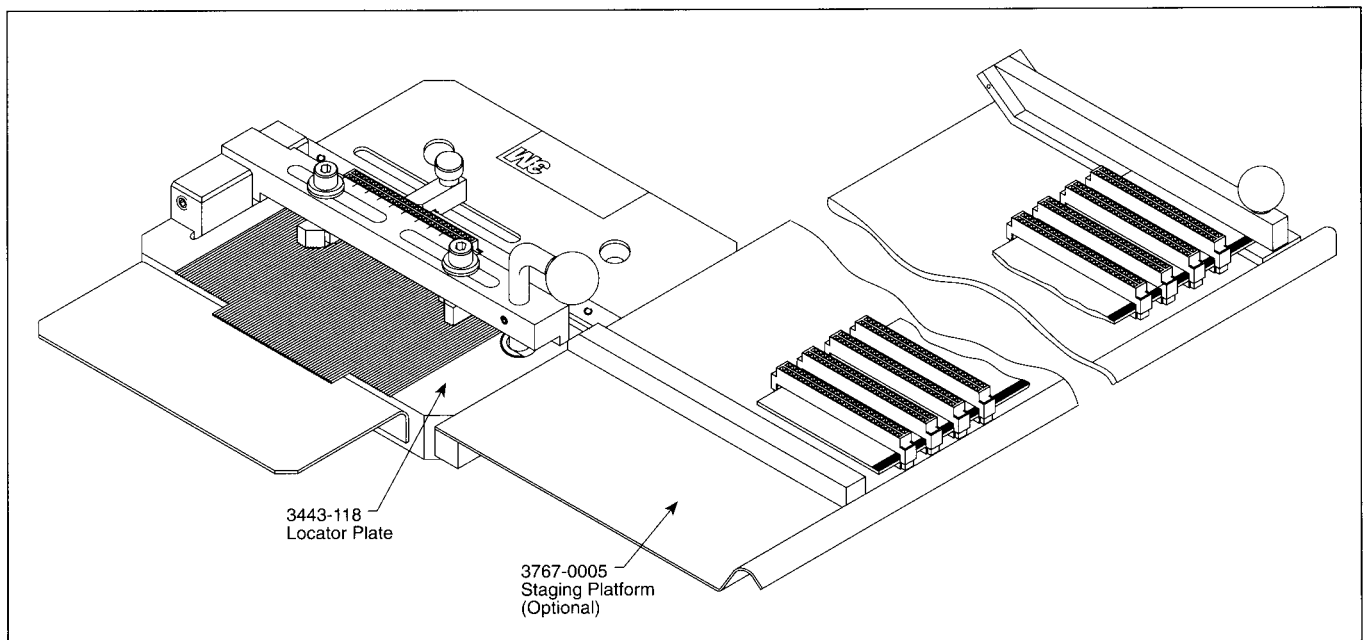

## Assembly procedure

1. Cut required cable length, using one of the 3M cable cutting tools.
2. Loosen the left cable guide screw ④. Lift the guiding wing ② and slide the left cable guide ④ into the required position depending on the connector size to be used. Connector pole sizes are indicated on guiding wing ②. Lower the guiding wing ② and make sure that the serrations of the base plate ⑤ and cable guide ④ are fully aligned. Tighten the cable guide locking screw.
3. Insert the appropriate cable ⑩ under guiding wing ② and adjust the right cable guide ⑥. Make sure that the base plate ⑤ and cable guide ⑥ serrations are aligned and that the right cable guide ⑥ is as close as possible to the cable ⑩.
4. Adjust the cable stop as required (see drawing). For daisy chain assemblies: left position ⑧. For end to end assemblies: right position ⑨.
5. Install platen 3442-1A.
6. Remove the connectors with the paper sword from the packing tray and place it on the staging platform with the socket body side up.
7. Slide the connector assembly off of the paper sword and into the guiding groove, against the connector locator stop ⑦.

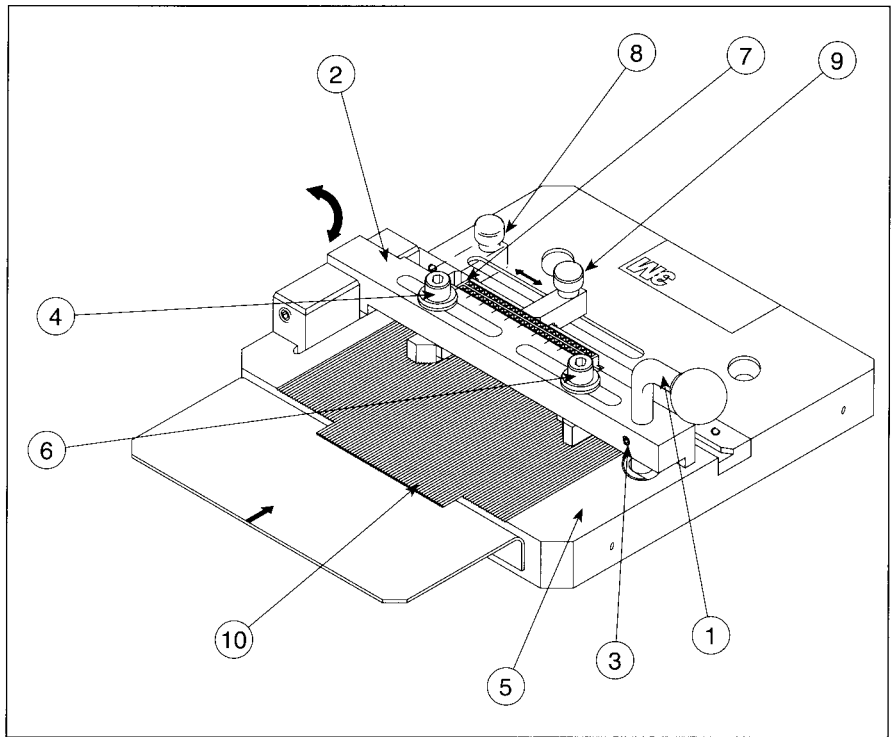

8. Place the cable ⑩ into the base plate serrations. For end assemblies smoothly slide the cable between cable guide ④⑥ under the guiding wing ② against the cable stop ③. For daisy chain assemblies, until the required length is obtained.
- Note:** If cable should not enter into the connector smoothly, please check flatness of the cable used.
9. Complete the assembly by closing the press handle.

- Note:** Never operate a pneumatic press without ensuring that there is a connector in the locator plate.
10. Raise press handle and remove the finished assembly by lifting the guiding wing ② with the lever ①.
  11. Visually inspect to ensure that:
    - a) The cover is fully locked. If not, check air pressure.
    - b) The cable is correctly aligned in the cover. If not, check cable guide adjustment

**Call 800-225-5373**

for sales and ordering information

### Important Notice

All statements, technical information and recommendations related to the Seller's products are based on information believed to be reliable, but the accuracy or completeness thereof is not guaranteed. Before utilizing the product, the user should determine the suitability of the product for its intended use. The user assumes all risks and liability whatsoever in connection with such use.

Any statements or recommendations of the Seller which are not contained in the Seller's current publications shall have no force or effect unless contained in an agreement signed by an authorized officer of the Seller. The statements contained herein are made in lieu of all warranties, express or implied, including but not limited to the implied warranties of merchantability and fitness for a particular purpose which warranties are hereby expressly disclaimed.

SELLER SHALL NOT BE LIABLE TO THE USER OR ANY OTHER PERSON UNDER ANY LEGAL THEORY, INCLUDING BUT NOT LIMITED TO NEGLIGENCE OR STRICT LIABILITY, FOR ANY INJURY OR FOR ANY DIRECT OR CONSEQUENTIAL DAMAGES SUSTAINED OR INCURRED BY REASON OF THE USE OF ANY OF THE SELLER'S PRODUCTS THAT WERE DEFECTIVE.